

Front-end LoRaWAN Gateway

Product Specification



Catalog

1. Description.....	- 3 -
2. Features.....	- 3 -
3. Application.....	- 3 -
4. Electrical specifications.....	- 4 -
5. Simple block diagram.....	- 4 -
6. Interface specifications.....	- 5 -
7. Power table.....	- 6 -
8. Pinout Description.....	- 7 -
9. Mechanical Dimension(Unit: mm).....	- 8 -

Note: Revision History

Revision	Date	Comment
V1.0	2018-01	First release
V1.1	2018-12	Correct the voltage
V1.2	2021-1	Update format

1. Description

This module is based on Semtech LoRaWAN concentrator reference design -- SX1301 Reference Board- PCB_E286V02A. It is a high performance LoRa/LoRaWAN module based on Semtech SX1301 and SX1255/1257.

The SX1301 digital baseband chip is a massive digital signal processing engine specifically designed to offer breakthrough gateway capabilities in the ISM bands worldwide. The LoRa concentrator is a multi-channel high performance transmitter/receiver designed to simultaneously receive several LoRa packets using random spreading factors on random channels. Its goal is to enable robust connection between a central wireless data concentrator and a massive amount of wireless end-points spread over a very wide range of distances.

The SX1301 is a smart baseband processor for long range ISM communication. In the receiver part, it receives I and Q digitized bitstream from one or two receivers (SX1255 as an example), demodulates these signals using several demodulators, adapting the demodulators settings to the received signal and stores the received demodulated packets in a FIFO to be retrieved from a MCU. In the transmitter part, the packets are modulated using a programmable (G)FSK/LoRa modulator and sent to one transmitter (SX1255 as an example). Received packets can be time-stamped using a GPS input.

The SX1301 has an internal control block that receives microcode from the MCU. The microcode is provided by Semtech as a binary file to load in the SX1301 at power-on .

2. Features

- LoRa long range module technology
- Half-duplex
- Simultaneously receive LoRa packets
- Dual digital Tx & Rx radio front-end
- Dynamic data-rate adaptation (ADR)
- Multi LoRa Spreading Factor
- Maximum 10 channels
- 8 x Multi SF LoRa channels (SF7 to SF12 with 125kHz Bandwidth)
- 1x LoRa channel (Bandwidth 125/250/500kHz)
- 1 x FSK channel

3. Application

- Smart city
- Smart Metering (Water, Electric, Gas meter)
- Agricultural Monitoring
- Irrigation control

- Internet of Things (IoT)
- M2M
- Wireless Sensors
- Wireless Alarm and Security Systems

4. Simple block diagram

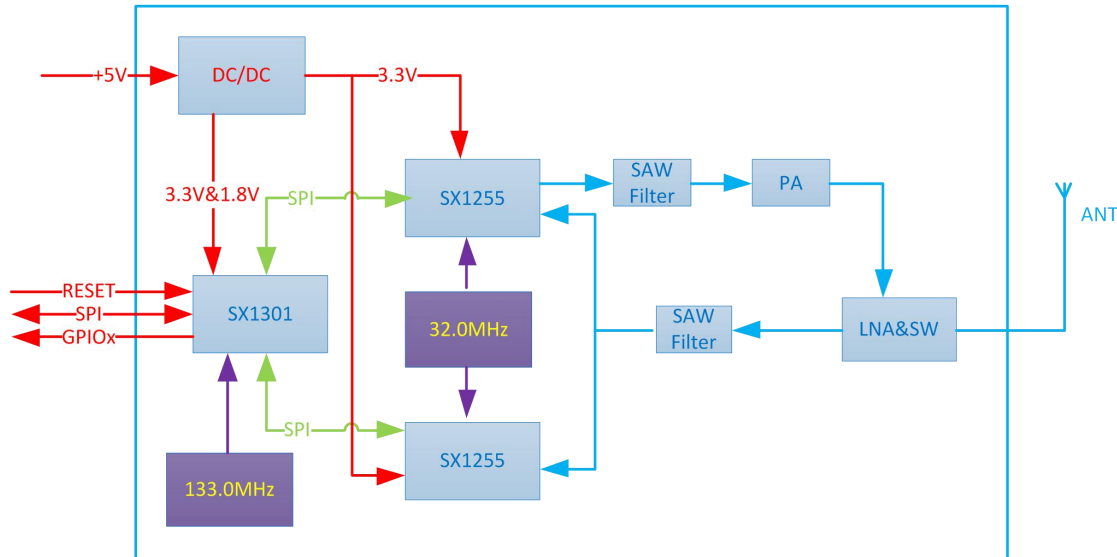

5. Electrical specifications

Parameter	Min	Typ.	Max	Unite	Condition
Working Condition					
Working voltage range	2.9	5.0	5.5	V	
Temperature voltage	-40		85	°C	
Current Consumption					
Receiving current		<340		mA	@9 channels all open
Transmitting current		<480		mA	@24dBm
Sleep current		<35		mA	
Parameter					
Frequency range	429	433	440	MHz	@433MHz
	470	480	490	MHz	@470MHz
	860.75	868.3	874.5	MHz	@868MHz
	902	915	928	MHz	@915MHz
Output power range	0		24	dBm	
Receiving sensitivity		-133		dBm	@SF=10,,BW=125kHz

6. Interface specifications

➤ Power-up sequence

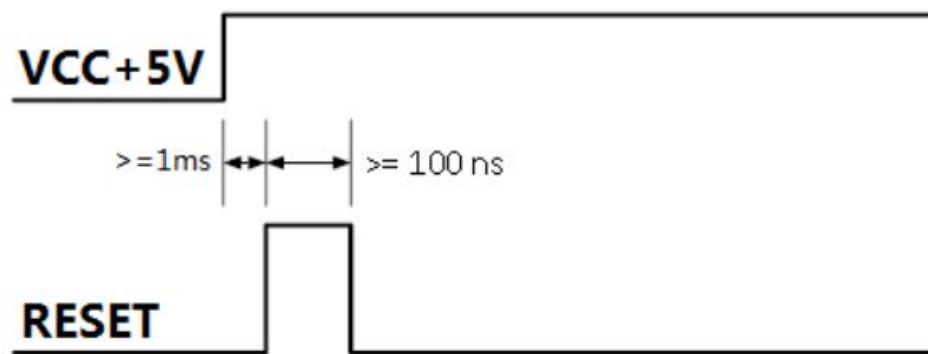

➤ SPI Timing

Parameter	Symbol	Conditions	Min	Typ	Max	Unit
SPI						
SCK frequency	F_{SCK}		-	-	10	MHz
SCK high time	t_{ch}		50	-	-	ns
SCK low time	t_{cl}		50	-	-	ns
SCK rise time	t_{rise}		-	5	-	ns
SCK fall time	t_{fall}		-	5	-	ns
MOSI setup time	t_{setup}	From MOSI change to SCK rising edge.	10	-	-	ns
MOSI hold time	t_{hold}	From SCK rising edge to MOSI change.	20	-	-	ns
CSN setup time	t_{nsetup}	From CSN falling edge to SCK rising edge	10	-	-	ns
CSN hold time	t_{nhold}	From SCK falling edge to CSN rising edge, normal mode	40	-	-	ns
NSS high time between SPI accesses	t_{nhigh}		40	-	-	ns

➤ Reference Design

Hardware Abstraction Layer (HAL)

The control of the SX1301 by the MCU is made using a Hardware Abstraction Layer (HAL). The Hardware Abstraction Layer source code is provided by Semtech and can be adapted by the MCU developers. It is recommended to fully re-use the latest HAL as provided by Semtech on https://github.com/Lora-net/lora_gateway.

7. Power table

➤ 434M TX Power Table:

TXLUT INDEX	TX POWER(dBm)	DIG	DAC	PA	MIX
0	1	0	3	1	12
1	2	0	3	1	13
2	3	0	3	1	14
3	4	0	3	1	15
4	5	0	3	2	10
5	7	0	3	2	11
6	9	0	3	2	12
7	10	0	3	2	13
8	12	0	3	2	14
9	14	0	3	3	10
10	16	0	3	3	11
11	18	0	3	3	12
12	20	0	3	3	13
13	22	0	3	3	15

➤ 868M TX Power Table:

TXLUT INDEX	TX POWER(dBm)	DIG	DAC	PA	MIX
0	0	0	3	1	8
1	2	0	3	1	9
2	4	0	3	1	10
3	6	0	3	1	12
4	7	0	3	2	8
5	10	0	3	2	9
6	11	0	3	2	10
7	14	0	3	2	12
8	16	0	3	3	8
9	18	0	3	3	9
10	20	0	3	3	10
11	22	0	3	3	12
12	23	0	3	3	15

8. Pinout Description

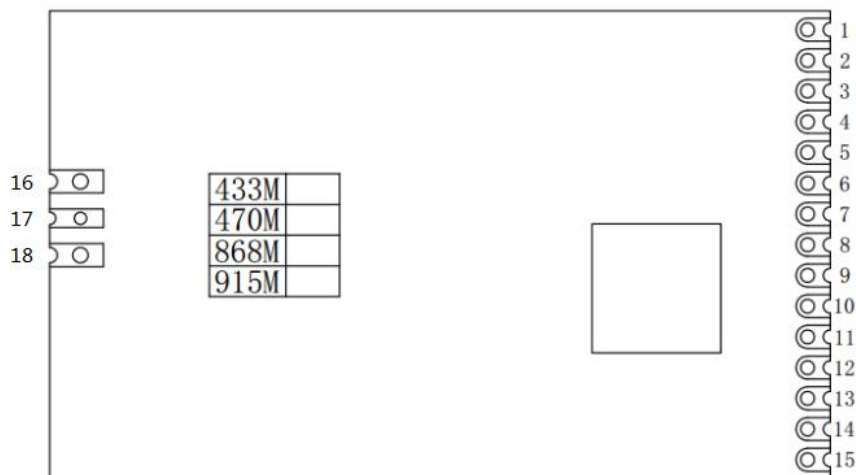

Pin	Definition	Type	Description
1	+5V	Power (VCC)	Power Supply
2	GPIO4	Input/Output	GPIO of SX1301
3	GPIO3	Input/Output	
4	GPIO2	Input/Output	
5	GPIO1	Input/Output	
6	GPIO0	Input/Output	
7	SCK	Input	SCK of SX1301 (max 10 MHz clock)
8	MISO	Output	MISO of SX1301
9	MOSI	Input	MOSI of SX1301
10	GPS_IN	Input	GPS_IN of SX1301
11	CSN	Input	CSN of SX1301
12	GND	Power (GND)	Ground
13	RESET	Input	Reset of SX1301
14	GND	Power (GND)	Ground
15	NC		Reserved
16	GND	GND of antenna	
17	Antenna	Antenna	
18	GND	GND of antenna	

9. Mechanical Dimension(Unit: mm)

